



Features

- High contact capacity in a compact package, up to 40A/250VAC
- Available in both open frame and plastic sealed package
- UL class F insulation system
- Applications: Industrial and home appliances, HVAC, etc

Safety Approval

US NO.E164730 NO.CQC08002027615
 NO.40009646 NO.50125641

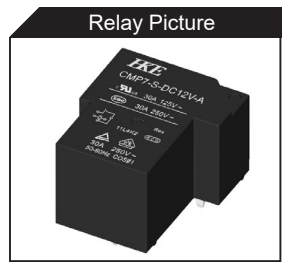

ORDERING INFORMATION

CMP7 - **S** - **DC12V** - **A** **T** *R

Remark: *R - Without common terminal

Model	Enclosure	Coil Voltage	Contact Form	Contact Rating
	S - Plastic Sealed Type Blank - Open Type	DC5V,DC6V,DC9V DC12V,DC24V,DC48V	A - 1 Form A C - 1 Form C	Blank - A:30A 250VAC/24VDC C:NO:20A 250VAC/24VDC NC:15A 250VAC/24VDC T - A:40A 250VAC/24VDC C:NO:40A 250VAC/24VDC NC:30A 250VAC/24VDC

SPECIFICATION

CONTACT DATA

Contact Form	1 Form A, 1 Form C		
Contact Material	Ag Alloy		
Contact Rating	A : 30A 250VAC/24VDC AT : 40A 250VAC/24VDC C : NO: 20A 250VAC/24VDC NC: 15A 250VAC/24VDC CT : NO: 40A 250VAC/24VDC NC: 30A 250VAC/24VDC		
Contact Resistance	Max.100mΩ(6VDC 1A)		
Load	Max. Switching Voltage	250VAC/28VDC	
	Max. Switching Current	40A(T)	30A
	Max. Switching Power	10,000VA,560W	7,500VA,560W
	Min. Switching Load	5VDC,100mA	
Life	Electrical	100,000次	
	Mechanical	10,000,000次	

GENERAL DATA

Insulation Resistance		Min.1000MΩ 500VDC
Dielectric Strength	Between open contacts	1,500VAC,1min
	Between coil and contacts	2,500VAC,1min
Operate Time		Max.15ms
Release Time		Max.10ms
Operating Temperature		-40°C to +85°C
Humidity		35~95%RH, +40°C
Shock Resistance	Endurance	1,000m/s ²
	Misoperation	100m/s ²
Vibration Resistance	Endurance	10~55Hz, 1.5mm double amplitude
	Misoperation	10~55Hz, 1.5mm double amplitude
Weight		Approximately 27.0g

Note:Data shown are of initial value

COIL DATA

Nominal Coil Power	900mW
--------------------	-------

SAFETY APPROVAL

File Number	Contact Form	Power Consumption	Coil Voltage	Contact Rating	Remarks
UL E164730	C	0.9W	5-48VDC	NO/NC: 20A/15A 125VAC	Class F insulation Ambient Temperature: 85°C
	A	0.9W	5-48VDC	30A 125VAC	
	CT	0.9W	5-48VDC	NO/NC: 40A/30A 250VAC	Class F insulation Ambient Temperature:40°C
	AT	0.9W	5-48VDC	40A 250VAC	
	C	0.9W	5-48VDC	B300	
CQC08002027615 (GB/T 21711.1-2008)	A	0.9W	5-48VDC	C300 R300	Class F insulation Ambient Temperature: 85°C
	A	0.9W	5-48VDC	30A 250VAC	
	C	0.9W	5-48VDC	NO/NC:20A/15A 250VAC	Ambient Temperature: 85°C
	AT	0.9W	5-48VDC	40A 250VAC	Ambient Temperature: 40°C

ISO9001、IATF16949、ISO14001 Approved

SAFETY APPROVAL

File Number	Contact Form	Power Consumption	Coil Voltage	Contact Rating	Remarks
VDE 40009646	A	0.9W	5 - 48VDC	30A 250VAC	Ambient Temperature: 70°C
	C	0.9W	5 - 48VDC	NO: 20A 250VAC NC: 15A 250VAC/24VDC	
TUV 50125641-0001	A	0.9W	5 - 48VDC	30A 250VAC	Ambient Temperature: 85°C
	C	0.9W	5 - 48VDC	NO/NC: 20A/15A 250VAC	
TUV 50125641-0002 (EN 60730-1)	A	0.9W	5 - 48VDC	30(8)A 250VAC	Ambient Temperature: 85°C
	C	0.9W	5 - 48VDC	NO/NC: 20(4)A/15(3)A 250VAC	

Specifications subject to change without notice

COIL DATA

Ambient Temperature: 23°C

Model	Nominal Voltage VDC	Coil Resistance Ω +/-10%	Operate Voltage \leq VDC	Release Voltage \geq VDC	Coil Power mW
CMP7-S-DC5V	5	27.8	3.5	0.5	900
CMP7-S-DC6V	6	40.0	4.2	0.6	
CMP7-S-DC9V	9	90.0	6.3	0.9	
CMP7-S-DC12V	12	160	8.4	1.2	
CMP7-S-DC24V	24	640	16.8	2.4	
CMP7-S-DC48V	48	2560	33.6	4.8	

OUTLINE, WIRING DIAGRAM, MOUNTING HOLE LAYOUT (UNIT: mm)

CMP7-DC××V-C
CMP7-S-DC××V-C

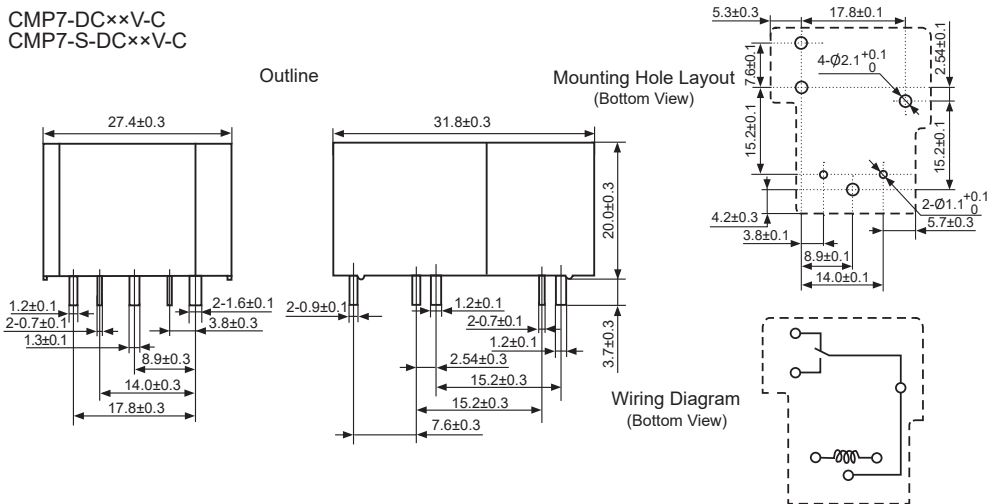

CMP7

POWER RELAY

OUTLINE, WIRING DIAGRAM, MOUNTING HOLE LAYOUT (UNIT: mm)

CMP7-DC××V-C-R
CMP7-S-DC××V-C-R

Outline

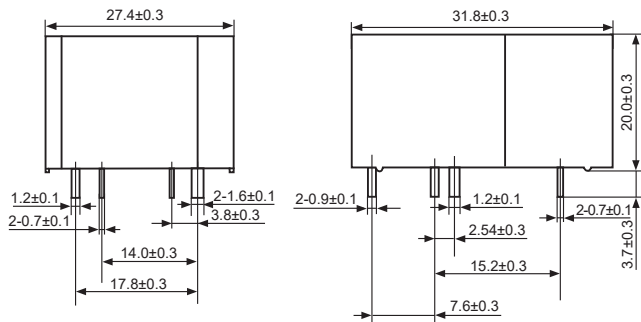

Mounting Hole Layout
(Bottom View)

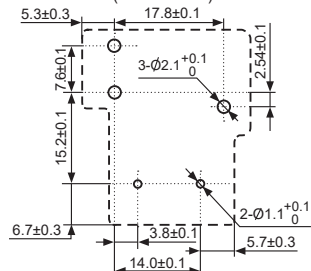

Wiring Diagram
(Bottom View)

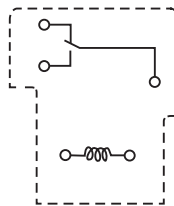

CMP7-DC××V-A
CMP7-S-DC××V-A

Outline

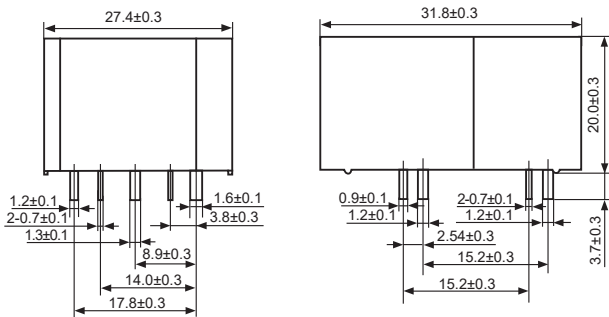

Mounting Hole Layout
(Bottom View)

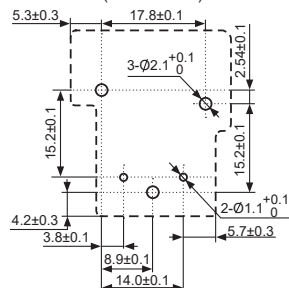

Wiring Diagram
(Bottom View)

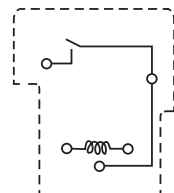

OUTLINE, WIRING DIAGRAM, MOUNTING HOLE LAYOUT (UNIT: mm)

CMP7-DC××V-A-R
CMP7-S-DC××V-A-R

Outline

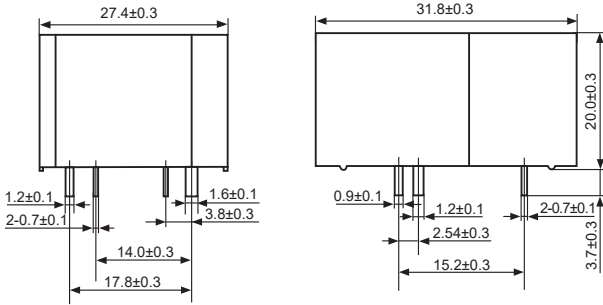

Mounting Hole Layout (Bottom View)

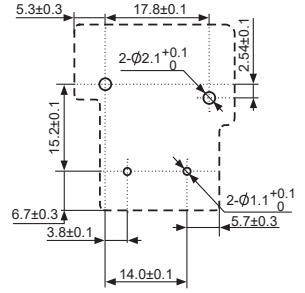

Wiring Diagram (Bottom View)

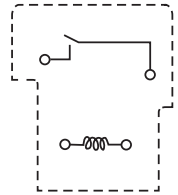

REFERENCE DATA

Time Curve

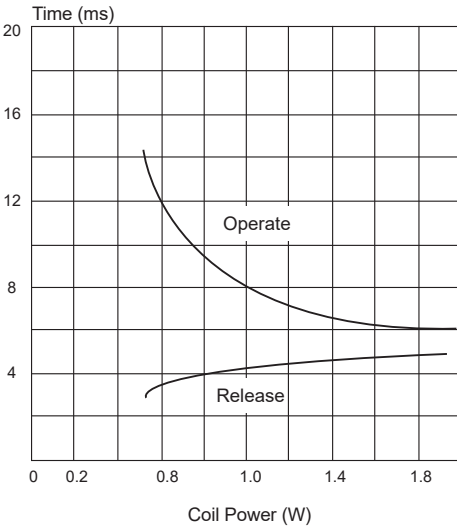

Coil Temperature Rise

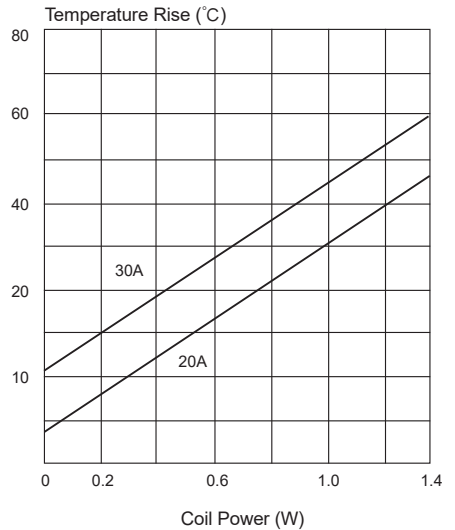

REFERENCE DATA

Maximum Switching Power

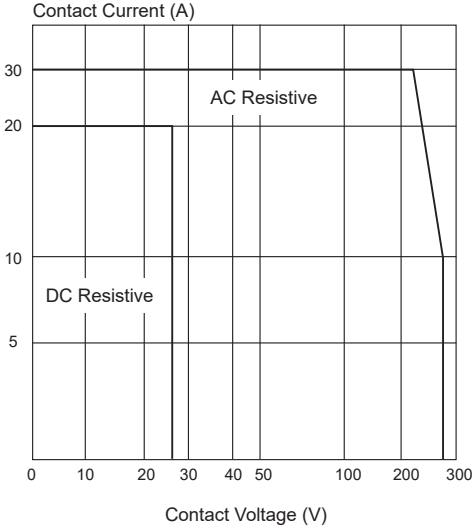

Life Curves

